



System Verification using SoundCheck™

This document will enable users of SoundCheck to verify their PC-based electroacoustic test and system is working properly.

Verifying Sound Card Performance

1. Choose “Self Calibration” sequence located in the Calibration Folder

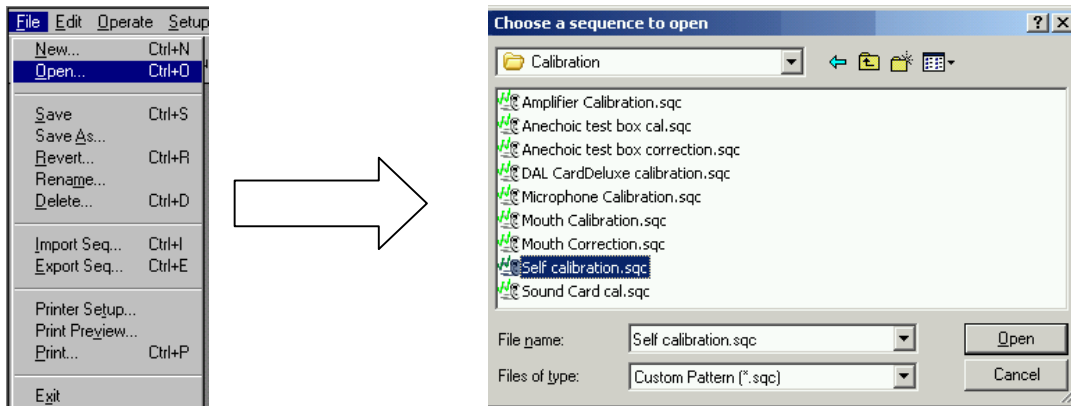

After clicking “Open”, this sequence will be loaded and will become the active sequence. The main SoundCheck screen should look like this:

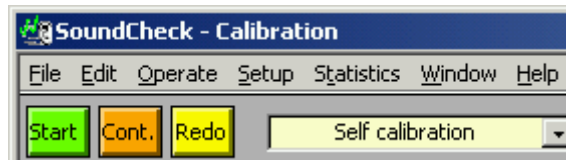

- Connect sound card input and output channels per the wiring diagram below:

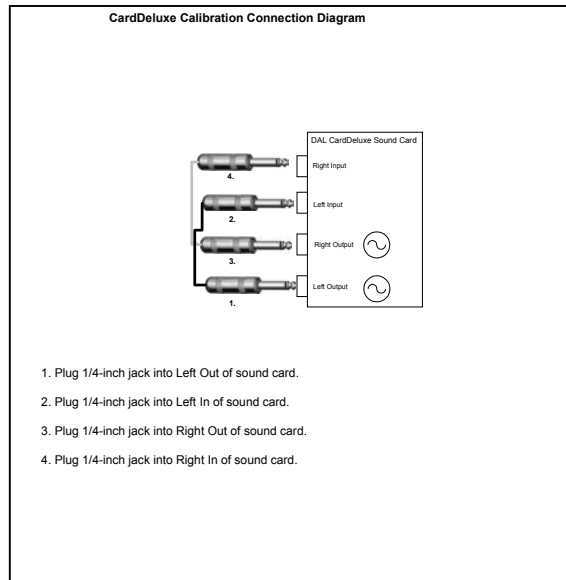

- Run the Self Calibration sequence by clicking on “Start”

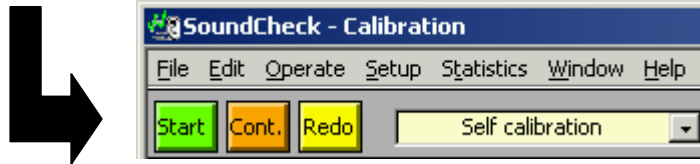

The sequence will then display the frequency response of the sound card’s right and left channel. If the sound card is operating properly, the frequency response will be within 0.2 dB re 1.00 volt.

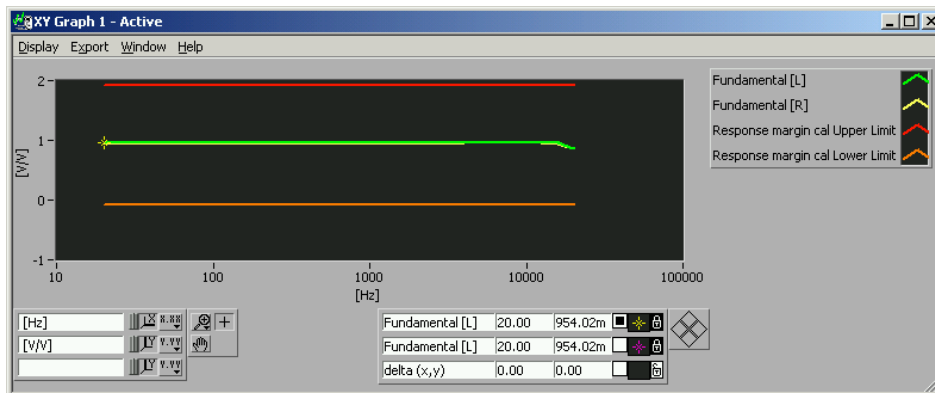

Properly working DAL CardDeluxe sound card

Detailed Frequency Analysis of Sound Card/Electrical Signal Path

Even though the CardDeluxe frequency and phase response may be within spec, ground loops may occur. A more detailed analysis can be done using the built-in signal generator and FFT functions within SoundCheck.

- Open the Signal Generator and FFT virtual instruments by clicking on “Operate” and click on Sine Generator and Spectrum Analyzer. You can also use the keyboard shortcuts (Ctrl + F4 and Ctrl + F7).

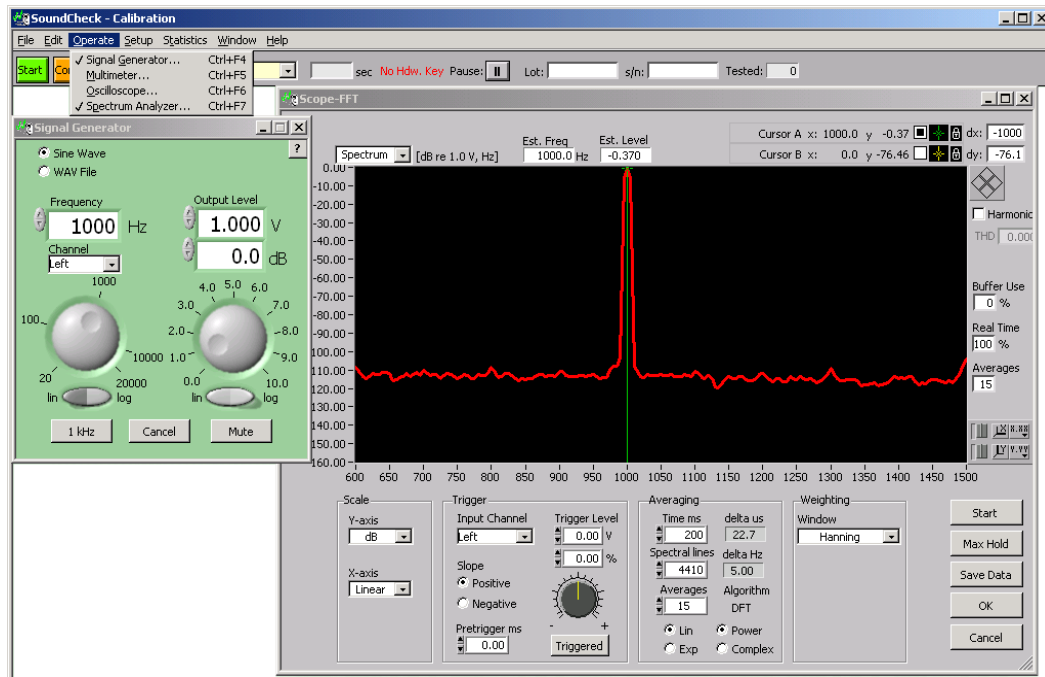

2. Set the Generator Output Level to 1.000V, Frequency to 1000, and Channel to Left.
3. Set FFT controls as shown in figure above except that Input Channel will be set to Left.
4. Click on Mute in Sine Generator so it no longer is blinking red. A 1.000 volt 1 kHz sine wave will be played from Left Out to Left In. Click Start on the FFT screen and the frequency spectrum will appear. If the sound card and interconnecting cables are in good working condition, the FFT spectrum should look like the one above. The sound card noise floor should be -100 to -110 dBV.

To check for any ground loops or electrical line frequency interference (50Hz or 60Hz), reduce the frequency range of the FFT display from 10 kHz to 1 kHz. To do this, place the mouse cursor over the 10000 number and highlight it by double-clicking using the left mouse button. Enter 1000 and then press the “Enter” key on the computer keyboard. The display will look like this:

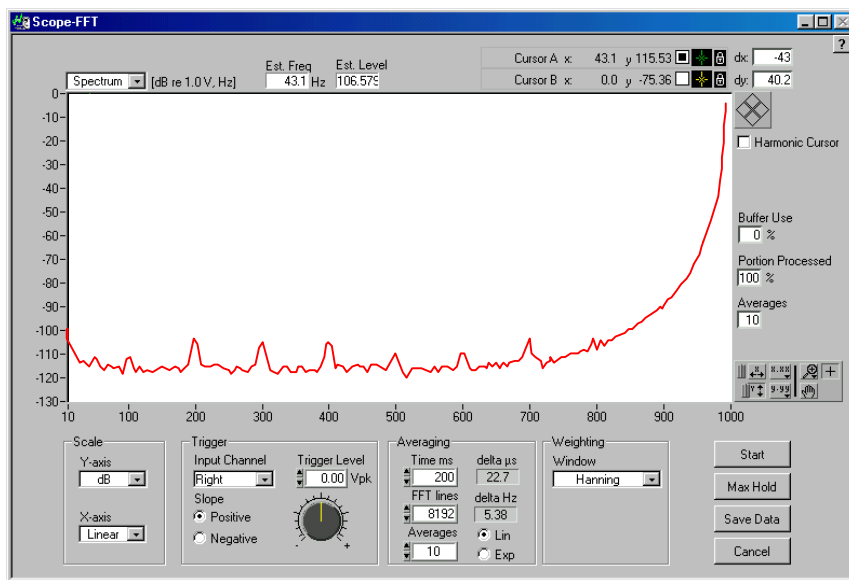

If there is any electrical interference, there will be significant spikes at 60 Hz (or 50 Hz) and associated harmonics. To check the right channel performance, simply change “Left” to “Right” on the Generator and FFT screens.

Verifying SoundConnect™ Performance

Checking the performance of the SoundConnect is similar to checking the sound card performance. The Gain & RSP sequence (Located in the Electronics folder) will be used as well as the Generator and FFT virtual instruments. The only difference is the wiring connections.

1. Connect the sound card to SoundConnect as shown in diagram below:

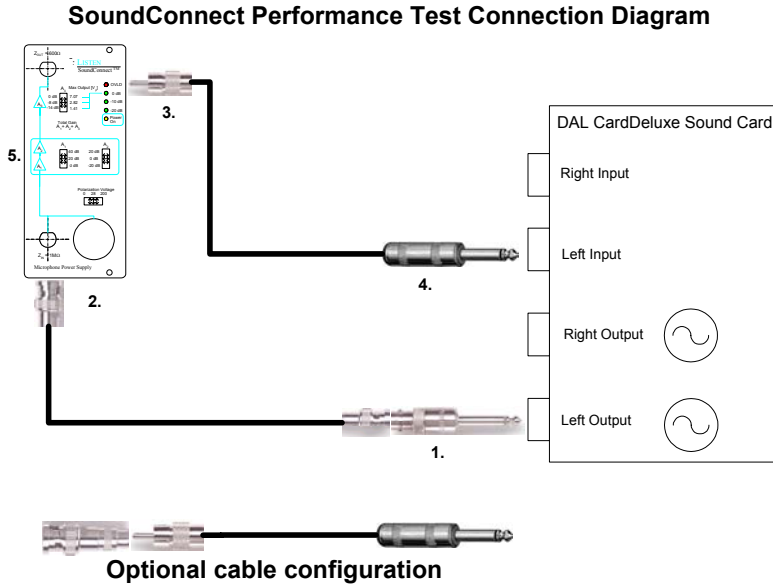

1. Plug 1/4-inch-to-BNC adapter jack into Left Out of sound card.
2. Plug a BNC-to-BNC cable from adapter to the BNC input of front panel of SoundConnect.
3. Plug RCA phono connector to back of SoundConnect
4. Plug 1/4-inch jack into Left In of sound card.
5. Set A_1 , A_2 , and A_3 switches to 0 dB.

NOTE: A 1/4-inch male to BNC adapter may be difficult to obtain. This can be substituted with a 1/4 inch-to-RCA cable and then using a female RCA (phono) to BNC adapter.

Run the Gain & RSP sequence and then run the Generator/FFT in the same manner when checking the sound card performance. The SoundConnect frequency should be very flat (less than 1.0 dB variation) and the FFT spectrum should only have a 1 kHz signal. If any harmonics are present, they should be at least 60 dB below the 1 kHz level.