



Sequence Note

TIA 810-B: Measurement of Narrowband Digital Phones (Part Number 3108)

Introduction

TIA 810-B is a comprehensive US standard for measuring narrowband digital phones. Handset, headset and speakerphone functions are all included. The standards apply to VoIP phones, as well as USB audio devices such as headsets, speakerphone attachments, and webcams. The module is a large structured set of sequences and subsequences which perform all the measurements. Curves and values are shown on the screen, tolerance checks are performed, and data is saved to Excel spreadsheet files. Completely prompted sequences for calibration of all the transducers are included. After a one-time setup with a sound card and other user-specific interfaces, the sequences are automatic. They run by simply selecting, pressing start, and following prompts where user interaction with the device under test is required. The sequence works with approved sound cards for connection to the transducers. Windows audio devices such as USB headsets work directly with SoundCheck[®]. VoIP softphones also work with SoundCheck, by means of a recommended third-party Windows audio application.

Required Equipment

Hardware

Head and Torso Simulator with handset positioner
Mouth Simulator
Power amplifier (if needed to power mouth simulator)
SoundConnect Microphone Power Supply
SCM microphone or equivalent
Acoustic calibrator
Telephone interface, for VoIP, digital, or other system

Software

SoundCheck 7.0 Telephone Testing R&D Package Part Number 1105 or alternative package including:
2005 RTA
2013 Wave file equalization
2007 Loudness rating
2009 Statistics

Note: This sequence has only been verified to work with SoundCheck version 7. If you are using a different version, please check with your sales engineer before purchasing.

Setup and calibration

Due to the complex nature of this sequence, please refer to the detailed instructions that are provided as part of the package

Handset Measurement Results

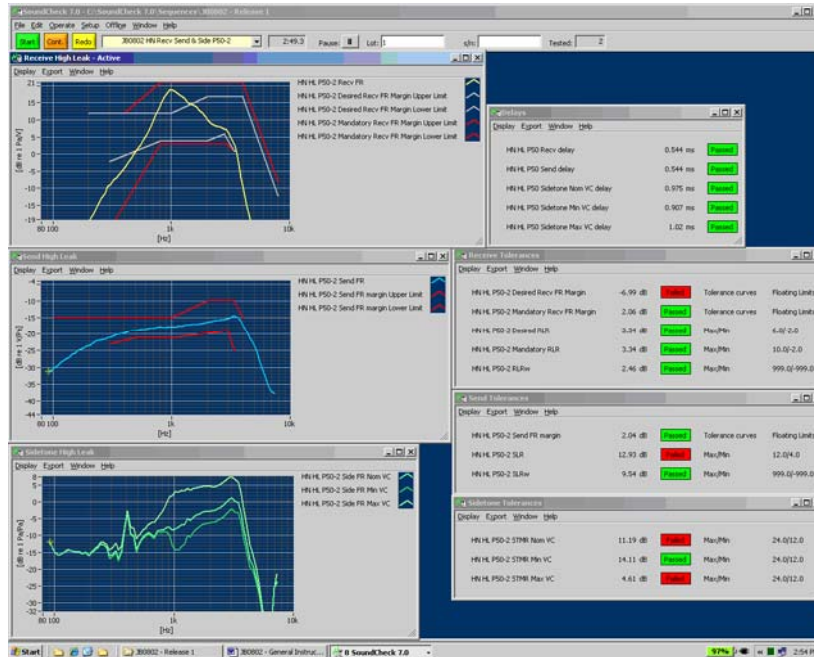

Test Results for Handset Measurement

System diagram for Handset Measurement

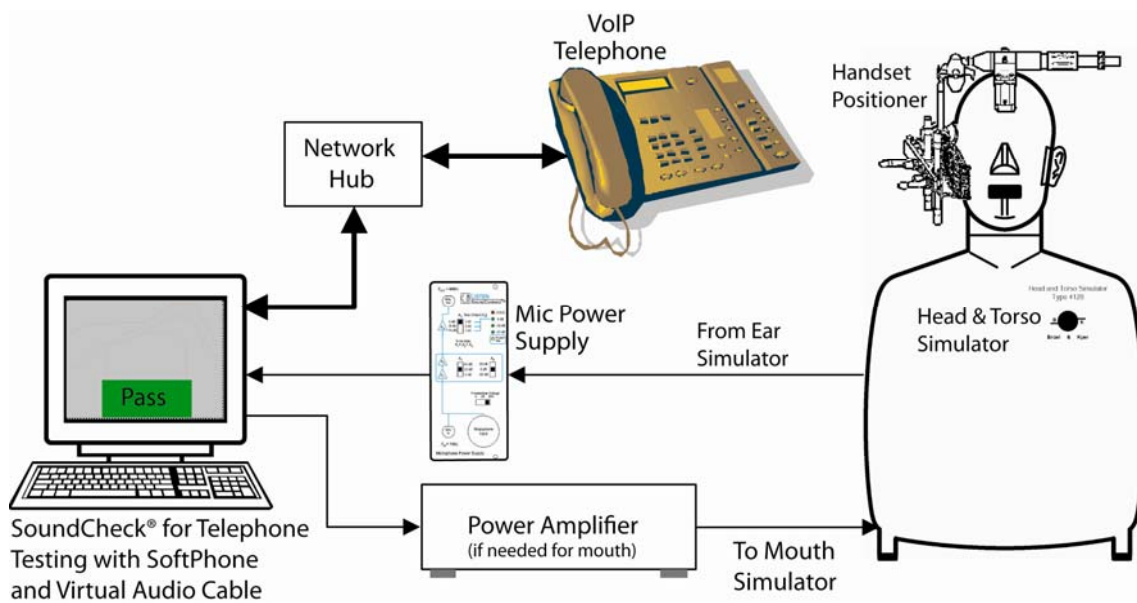

Headset Measurement Results

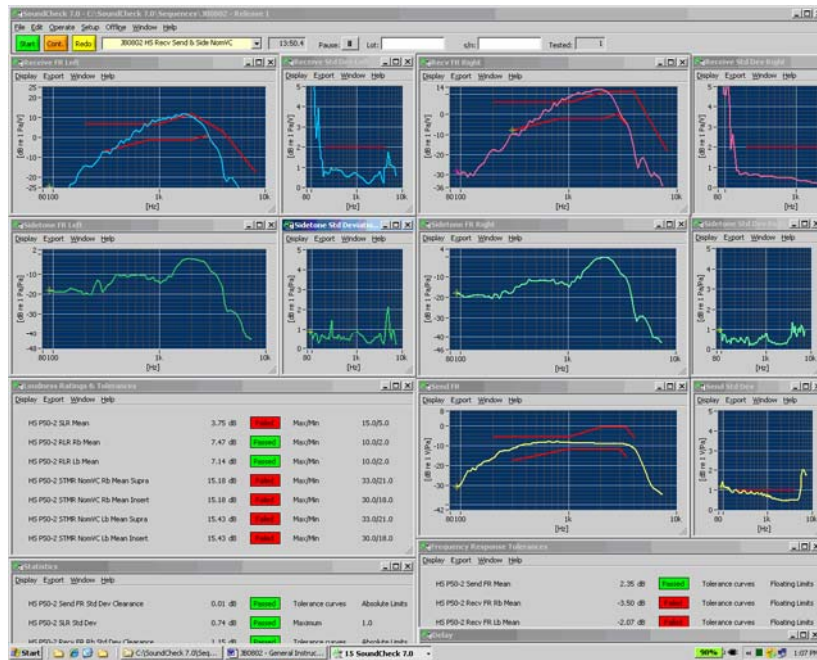

Test Results for Headset Measurement

System diagram for Headset Measurement

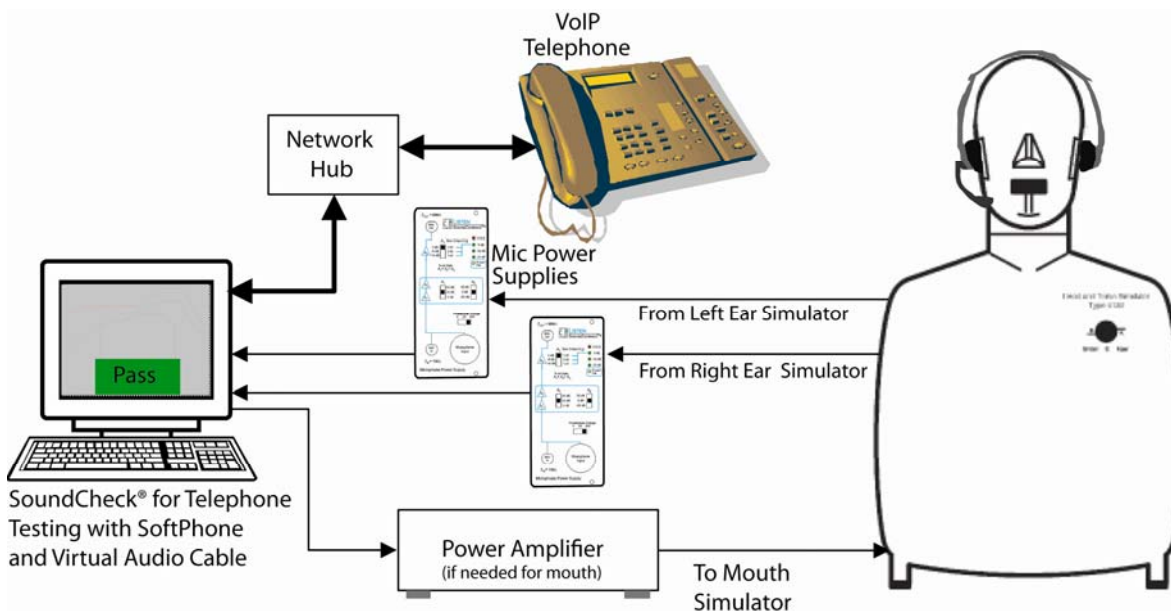

Speakerphone Measurement Results

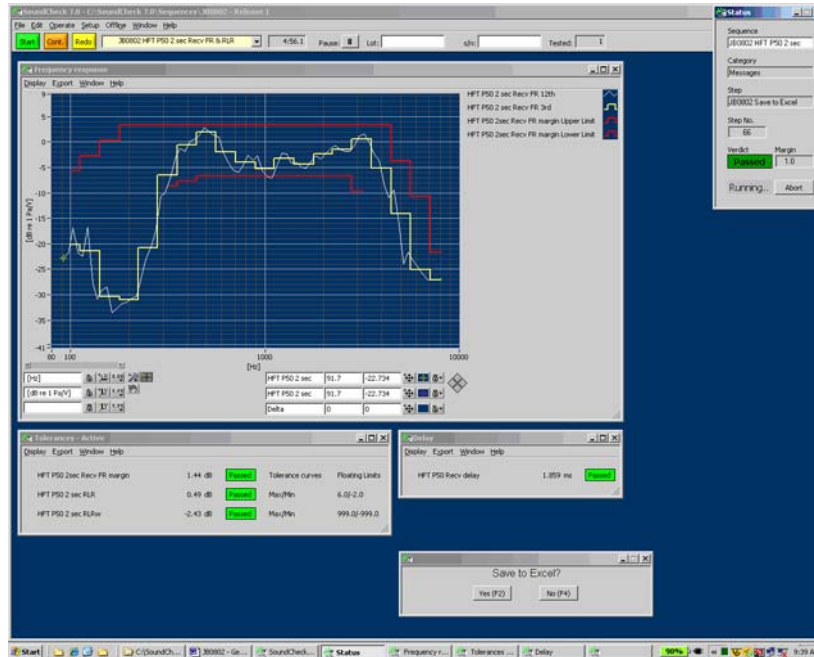

Test Results for Speakerphone Measurement

System diagram for Speakerphone Measurement

